

Introduction

This small and affordable FPGA module has been designed by ALSE to replace the Cyclone III DBM Modules from Devboards.de that became unavailable and didn't allow the use recent versions of Quartus.

ADM is compatible with DBM3C modules : it can be plugged in the same baseboards. We developed this simple module for our own needs including a Gigabit Ethernet concentrator driving multiple remote controllers through optical fibers.

This module can be helpful for similar applications that were developed for older DBM modules, thus we made it available on the shelf. The Max10 FPGA also offers 2 x ADC (Analog to Digital Converters) not available on the original modules.

Note however that this module does not implement the external memory nor the external Flash as compared to the original DBM modules, so it is not functionally equivalent and may not be suitable for any replacement. An analysis of the features used by the DBM design is necessary to verify if ADM can be used as a replacement.

ADM is well suited for Ethernet connectivity applications, especially when using ALSE's GEDEG IP.

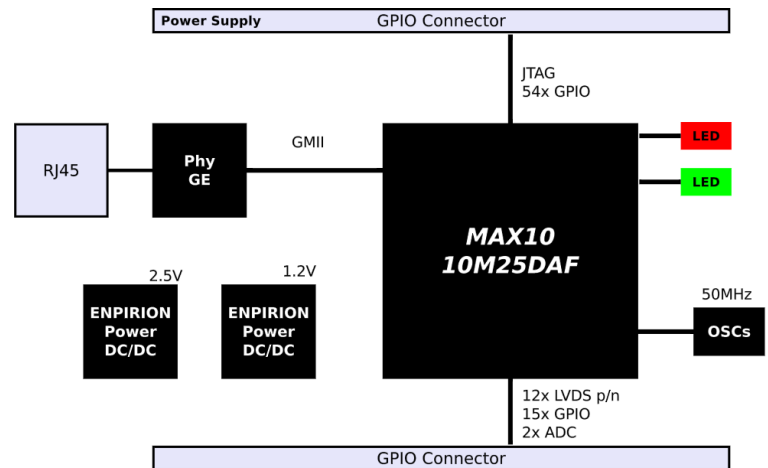
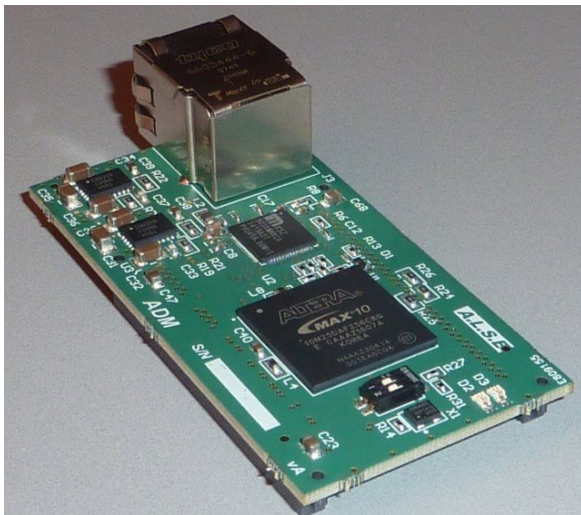

Main Features

- A Gigabit Ethernet PHY with RJ45 connector and activity LEDs is available for applications with Ethernet connectivity.
- 2 x internal ADCs
- Low Power: the board receives 3.3V from the connectors. Two on-board high-efficiency Enpirion switching regulators provide the internal voltages required.
- Internal non volatile Memory : the Max10 FPGA used on the board includes internal Flash memory that is used for FPGA configuration and may also be used for User applications.
- The board comes with a "Golden Top" entity and a Reference Design project with Ethernet connectivity (based on GEDEK IP, not included).
- ADM is available for purchase.

Typical Applications

- Process control, Regulation, Motor control...
- Ethernet control System
- Signal acquisition and processing
- Etc !

ALSE can develop very rapidly custom applications using the internal know-how and IPs, thus offering a ready-to-use solution, ready to plug and play. We can also *quickly design a baseboard* suited for your specific application.

Technical specifications

- FPGA: Altera Max10, 10M25DAF256C8G
- External Oscillator : 50 MHz
- ADCs : 2 (internal).
- External on-board Ram: none
- Gigabit Ethernet PHY: Micrel KSZ9031 (10/100/1000)
- 69 x GPIOs, 12 x LVDS in/out
- 2 x User LEDs + 2 DIP switches
- Power < 400mA (3.3V) with Gigabit active (240mA w/o)
- PCB : 6 layers.

Contact

A.L.S.E
8 passage Barrault
75013 – PARIS – France
Tel +33 1 84 16 32 32
info@alse-fr.com www.FPGA.fr